

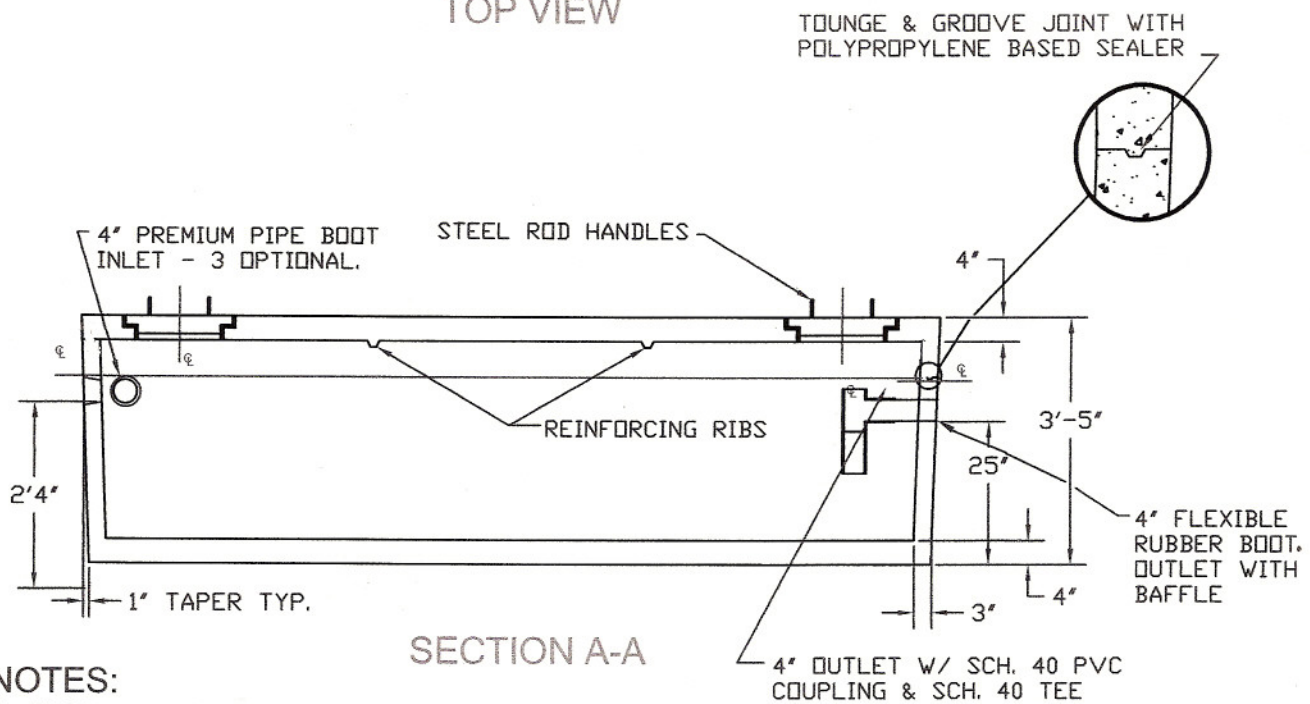

TOP VIEW



SECTION A-A

- NOTES:
1. EXCAVATION MUST BE AT LEAST 12" WIDER & LONGER THAN TANK SIZE.
 2. REINFORCED WITH 12.5 GA. GALVANIZED WIRE & 1/2" RE-ROD.

		Shallow 1000 Gal. - Booted.	
		SIZE A DATE 9/01/05 DRAWN BY: BRYON BUSH	DWG NO. 017 REV B SHEET 1 of 1

3584 Airline Road
Muskegon, Michigan 49444