

TOP VIEW

TONGUE & GROOVE
JOINT WITH
BITUMEN-BUTAL
BASED SEAL

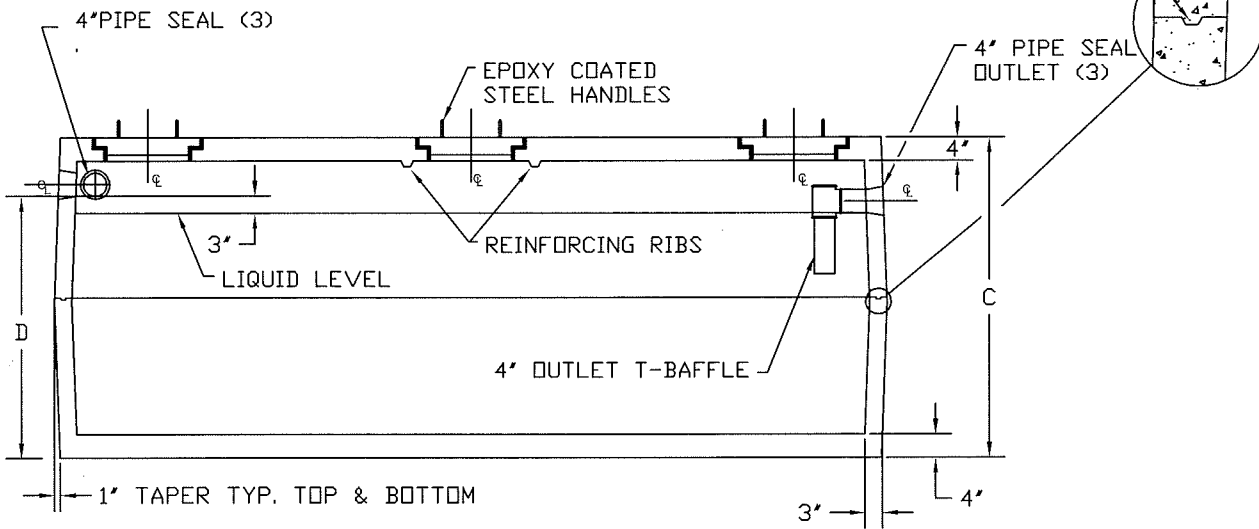

SECTION A-A

NOTES:

- EXCAVATION MUST BE AT LEAST 12" WIDER & LONGER THAN TANK SIZE.

* SEE PAGE 2 FOR CENTER SECTION DETAILS AND DIMENSIONS.



3584 Airline Road Muskegon, Michigan 49444
231-733-1904 1-800-TOO-BUSH
WWW.BUSHCONCRETEPRODUCTS.COM

1600-4000 gal. Septic Tank

SIZE	DATE	DWG NO.	REV
A	12/14/05	011	2/01/12
DRAWN BY: S. GARABEDIAN		SHEET	1 of 2

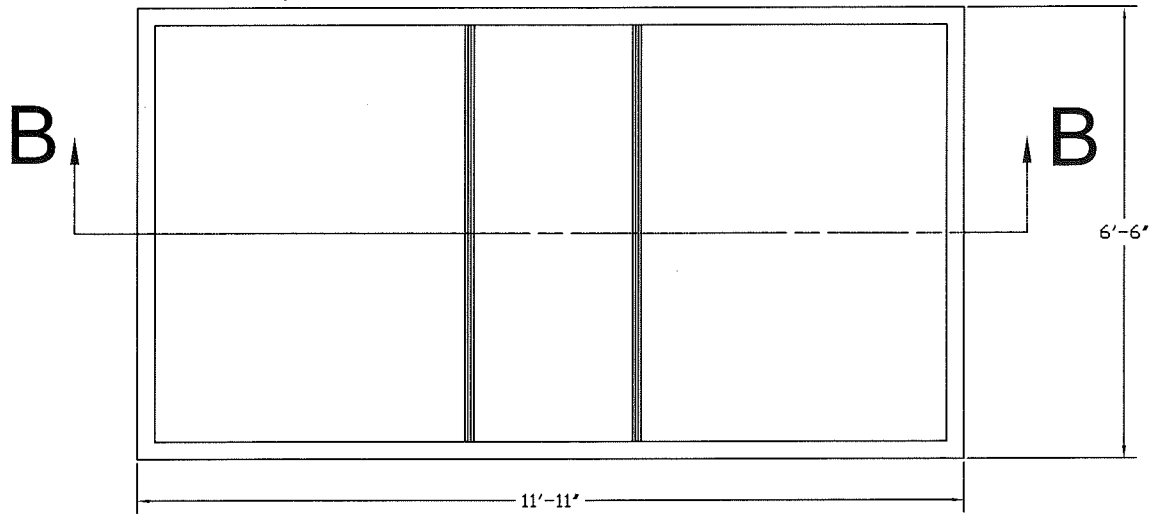

SPACER RING - TOP VIEW

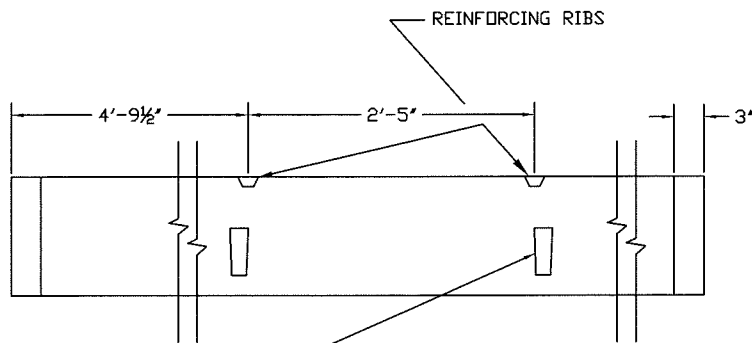

SECTION B-B

LIQUID GALS.	A	B	C	D
	WIDTH	LENGTH	HEIGHT	INVERT
1600	6'-6"	11'-11"	5'-0"	4'-0"
1800	6'-6"	11'-11"	5'-4"	4'-4"
2000	6'-6"	11'-11"	5'-8"	4'-8"
2600*	6'-6"	11'-11"	7'-2"	6'-2"
3000*	6'-6"	11'-11"	7'-10"	6'-10"
3600*	6'-6"	11'-11"	9'-4"	8'-4"
4000*	6'-6"	11'-11"	10'-0"	9'-0"



CONCRETE PRODUCTS, INC.

3584 Airline Road Muskegon, Michigan 49444
 231-733-1904 1-800-TOO-BUSH
 WWW.BUSHCONCRETEPRODUCTS.COM

1600-4000gal. Septic Tank

SIZE	DATE	DWG NO.	REV
A	12/14/05	011	
DRAWN BY: S. GARABEDIAN		SHEET	2 of 2